

DYNALCO®

3211 Fruitland Ave
Los Angeles, CA 90058

SST7000

SST7100

Speed Switch / Transmitter

Installation and Operation Manual

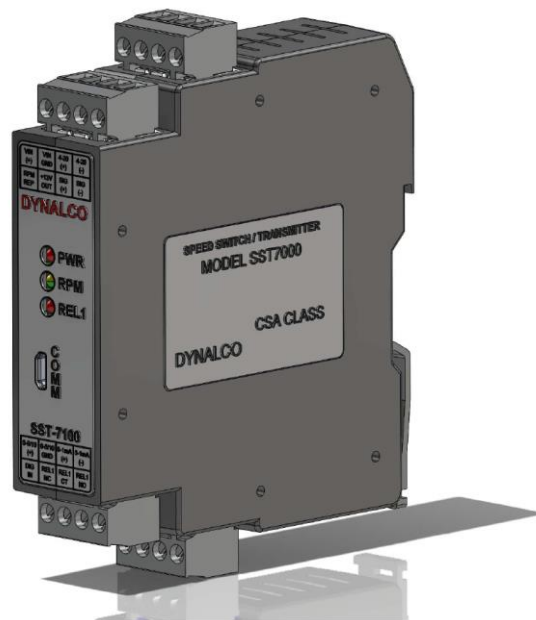

Rev. E

P/N145F-13091

PCO – 00010304

(c) Copyright 2015, Barksdale, Inc.

All Rights Reserved

Published: Oct 20, 2015

Barksdale®
CONTROL PRODUCTS
CRANE Barksdale, Inc./Barksdale GmbH
A Subsidiary of Crane Co.

IMPORTANT - PLEASE READ BEFORE PROCEEDING!

The Dynalco SST7000 series speed switch / transmitter is designed for reliable and rugged operation. This product has been designed and tested to meet the demands required in many industrial and hazardous locations meeting critical CSA standards. Performance of this product is directly related to the quality of the installation and knowledge of the user in operating and maintaining the instrument. To ensure continued operation to the design specifications, personnel should read this manual thoroughly before proceeding with installation, operation and maintenance of this instrument. If this product is used in a manner not specified by Dynalco, the protection provided by it against hazards may be impaired.



- Failure to follow proper instructions may cause any one of the following situations to occur: Loss of life; personal injury; property damage; damage to this instrument; and warranty invalidation.

- For clarification of instructions in this manual or assistance with your application, contact Dynalco as below:

Tech Support: DYN-TechnicalSupport@barsdale.com or 1-866-227-8528
Customer Care: BRK-DYN-CustomerCare@barsdale.com or 1-800-835-1060

Or by mail:

Barksdale Inc.
Barksdale and Dynalco Products
3211 Fruitland Ave
Los Angeles, CA 90058

- Additional manuals and CSA certificates are available at

- Follow all warnings, cautions, and instructions marked on and supplied with the product.
- Use only qualified personnel to install, operate, program and maintain the product.
- Educate your personnel in the proper installation, operation, and maintenance of the product.

- Install equipment as specified in the installation section of this manual. Follow appropriate local and national codes. Only connect the product to power sources and end devices specified in this manual.

- Any repair is only to be performed by Dynalco using factory documented components. Tampering or unauthorized substitution of parts and procedures

can affect the performance and cause unsafe operation of your process.

- All equipment doors must be closed and protective covers must be in place unless qualified personnel are performing maintenance.
- Shutdown / alarms should be tested monthly for proper operation (see page 15)
- Please see page 17 for CSA specific installation instructions.

This manual covers both models SST7000 and SST7100:

SST7000 **Speed Transmitter w/ 4 – 20 mA Output**

SST7100 **Speed Switch / Transmitter w/ 4 – 20 mA Output & Relay Trip**

System Overview

The SST7000 speed transmitter is a DIN rail mountable product designed to convert rotational speed (RPM) to an industry standard 4 – 20 mA analog output. The SST7100 also provides 1 relay trip output for over / under speed alarm or shutdown.

Both models will accept a pulsed input from either a 2 or 3-wire speed sensor.

Programming:

The host software allows programming of the SST7000 series via a USB connection to a PC.

Additional Features

- Repeater Output
- 0 – 1 mA local meter output
- 0 – 5 VDC / 0 – 10 VDC selectable proportional output
- Isolated 4 – 20 mA proportional output

Specifications

- 1) **INPUT SUPPLY VOLTAGE:** 10 - 36 VDC, maximum 10 W
- 2) **FREQUENCY INPUT:**
 - a. **Input Signal Frequency Range:** 0 – 50 KHz
 - b. **Waveforms:** Accepts sinusoidal or square wave (positive or zero-crossing)
 - c. **Input Signal Sensitivity:** 25 mV to 1.0 VRMS (selectable), Maximum allowed is 50 VRMS
 - d. **Input Impedance:** 10 K (minimum)
 - e. **CSA Approved Dynalco Sensors:** M201, M202, M231, M233, M203, M204, M205, M928 M928-24 & M951
- 3) **DIGITAL INPUT:** Dry contact closure for resetting latched relay
- 4) **OUTPUTS:**
 - a. **Meter Output:** 0 – 1 mA meter output for loads up to 750 ohms
 - b. **Proportional Output:** Proportional to input frequency range, configurable as:
 - i. 4 – 20 mA into maximum 1K load

And one of either:
 - ii. 0 – 5 VDC into 20K load or higher or
 - iii. 0 – 10VDC into 20K load or higher

Note that the 4 – 20 mA output is isolated but the 0 – 5 VDC & 0 – 10 VDC outputs are referenced to input supply ground. 0 – 1mA output is referenced to separate ground (Meter Output).
 - c. **Supply Output:** Regulated +12 VDC \pm 5%; 40 mA for active pickup power.
 - d. **Repeater Output:** Square wave 12 V peak-to-peak, 10 mA max load, Zero based, positive going.
 - e. **Response Time:** 50 milliseconds, 10% to 90% rise (standard)
Full-scale frequency ranges below 80 Hz are proportionally slower

10milliseconds, 10% to 96% rise (standard)
Full-scale frequency ranges below 300Hz are proportionally slower. For 10mSec response time the input frequency signal must be noise free.
 - f. **Linearity:** 0.1% of full-scale (0.05%, typical) all outputs
 - g. **Stability:** Less than 0.05% of full-scale change with a 10% change in supply voltage. Temperature coefficient \pm 0.01% per °F (\pm 0.018% per °C)

5) RELAY OUTPUT:	Applies to SST7100 only
a. Type:	SPDT relay contacts (isolated dry contacts)
b. Contact Rating:	6.0 Amps @ 28 VDC or 115 VAC 1/8 HP @ 120 / 240 VAC (100,000 cycles) 1.5 / 0.8 Amps @ 120 / 240 VAC, Pilot Duty (100,000 cycles) 3.8 / 1.9 Amps @ 120 / 240 VAC general Use (100,000 cycles)
c. Hysteresis:	Selectable (1% of full-scale frequency default)
d. Setpoints:	Programmable for: <ul style="list-style-type: none"> i. Overspeed / under speed trip ii. Energize or de-energize when setpoint reached iii. Latching or non-latching (auto reset) iv. Underspeed setpoints are Class C Logic (active once normal) v. Latched relays are reset via digital input
e. Stability:	Less than 0.05% of setpoint change with a 10% change in supply voltage. Temperature coefficient $\pm 0.01\%$ per $^{\circ}\text{F}$ ($\pm 0.018\%$ per $^{\circ}\text{C}$)
6) ALARM INDICATION:	
a. Open Pickup Alarm:	LED indication if open pickup sensed Option to trip relay (SST-7100 only)
b. Trip Indication:	LED indication if a relay tripped condition
7) MEMORY:	All configuration parameters retained if power lost
8) CONNECTORS:	Removable Phoenix type
9) MECHANICAL:	DIN rail mount package
10) ENVIRONMENTAL:	
a. Operating Temperature Range:	-40 to +70 DegC
b. Storage temperature:	-40 to +80 DegC
c. Vibration:	Per modified MILS STD 810-E
11) AGENCY APPROVAL:	CSA Class I, Div. 2, Groups A, B, C, D
12) PROGRAMMING	
a. PC / Windows based:	Windows XP, Vista & Windows 7 & 8 compatible USB port for programming, uploading & downloading

Installation:

The SST7000 series has an integral latch on the rear of the device for installation on a standard 35 mm DIN rail.

This device is OPEN type equipment that must be used within a suitable end-use system enclosure, the interior of which is accessible only through the use of a tool. The suitability of the enclosure is subject to investigation by the local Authority Having Jurisdiction at the time of installation.

Wiring to or from this device, which enters or leaves the system enclosure, must utilize wiring methods suitable for Class I, Division 2 Hazardous Locations, as appropriate for the installation.

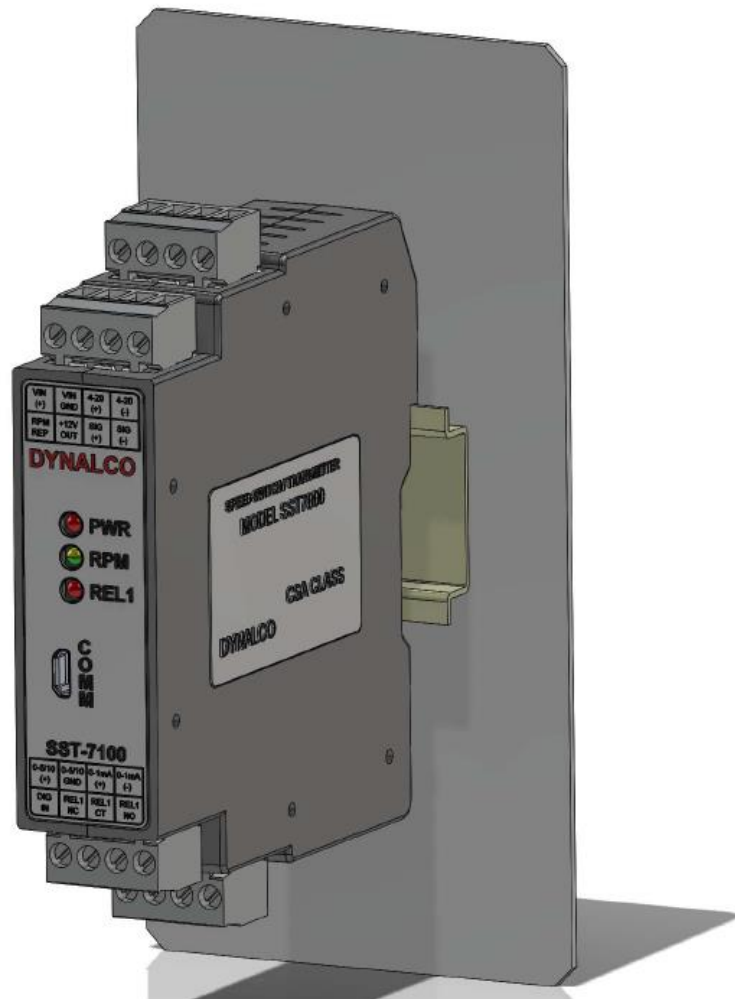

Terminal Connections

All connections are made via the terminal blocks on the front of the unit.

PIN	Description
VIN (+)	10 - 36 VDC Supply (+)
VIN GND	Supply Ground (-)
4-20 (+)	4-20 mA Proportional Output (+)
4-20 (-)	4-20 mA Proportional Output (-)
RPM REP	Repeater Output (+) (pulsed square wave)
+12V OUT	Power for 3-wire pickups
SIG (+)	Signal Input (+) from speed sensor
SIG (-)	Signal Input (-) from speed sensor

PIN	Description
0-5/10 (+)	0-5 or 0-10 VDC Proportional Output (+)
0-5/10 GND	0-5 or 0-10 VDC Proportional Output (-)
0-1mA (+)	0-1 mA local meter output (+)
0-1mA (-)	0-1 mA local meter output (-)
DIG IN	Digital Input for resetting latched relay (SST7100)
REL1 NC	Normally-Closed Relay Contact (SST7100)
REL1 CT	Relay Common (SST7100)
REL1 NO	Normally-Open Relay Contact (SST7100)

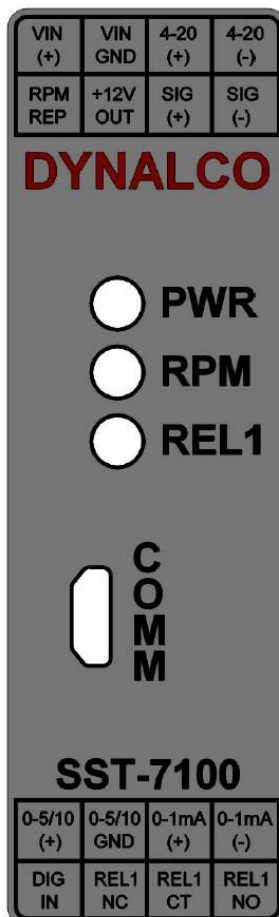
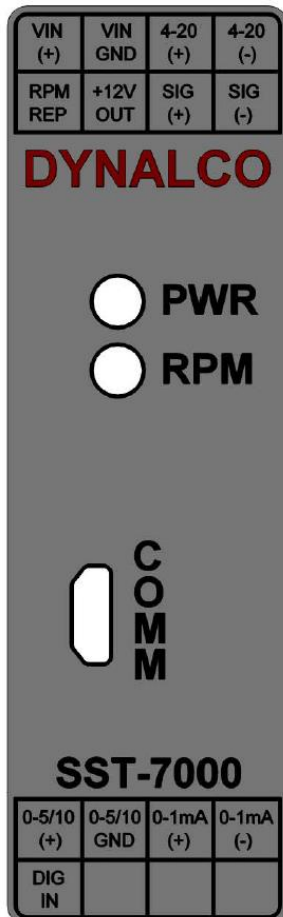

Terminal screws to be tightened to 4 inch-pounds torque.

Outline Dimensions

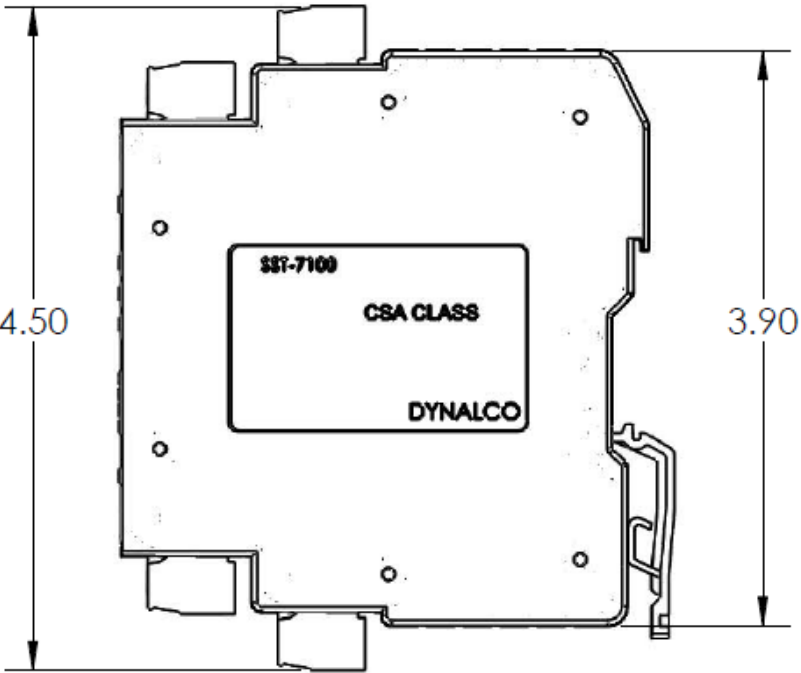
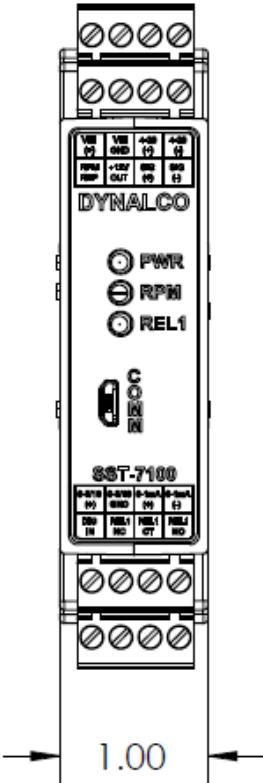
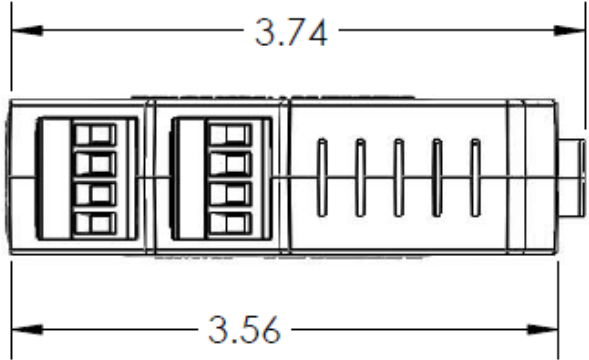

Dynalco SST7000 Series Software

The Dynalco host software provides serial communication between a PC or laptop and the SST7000 series. The software is compatible with Windows XP, Vista and Windows 7 operating systems. The SST7000 must be connected via provided Dynalco **P/N 270A-105574** serial communication cable.

The Dynalco host software is available as a free download from our website:

[downloads](#)

Following installation, a shortcut will be installed on your PC desktop. This application software allows access to various screens for configuration of input signal sensitivity, proportional output and relay logic / setpoints. Once the configuration parameters are set, they can be programmed into the SST7000 and a spec file can be saved to the PC. This saved spec file can then be loaded into another SST7000 if desired. Additionally, there is an import function allowing uploading of the spec file from an SST7000 to the PC.

Configuration consists of the steps described in the following pages:

RPM Signal

The RPM Signal needs to be programmed prior to all other settings.

The SST7000 series is capable of accepting input signals from 2-wire (also known as variable reluctance) magnetic pickups as well as 3-wire (powered, TTL or hall-effect) type sensors. The output from 2-wire pickups is an AC signal where the 3-wire type will normally have a positive-going (non zero-crossing) square wave output.

- Gear Teeth
 - Required to convert RPM to Hz for proper calibration
- Sensitivity Level
 - Set for Med-High for most applications
 - Higher level will allow greater sensitivity if needed for low speed applications
 - Lower level will be less sensitive to noise

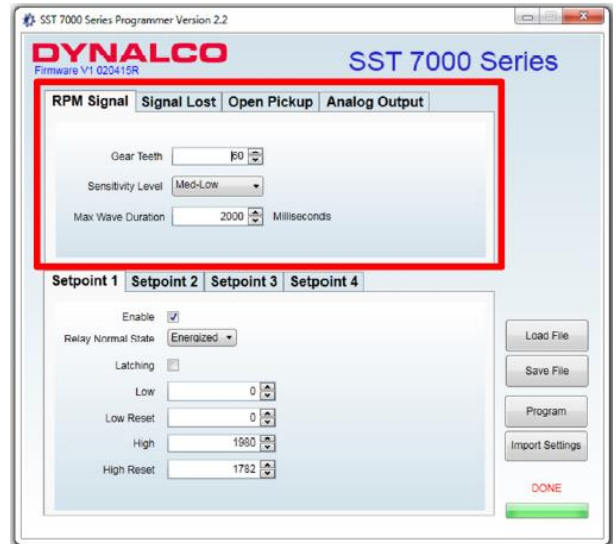

- Max Wave Duration
 - The Max Wave Duration is defined as the maximum time allowed between input signal pulses before a sensor fault is declared. For example, a shaft with 2 keyways turning at 0 – 10 RPM would have an extremely low frequency range, calibrated below:

$$\begin{aligned}\text{Frequency} &= \text{RPM} \times \# \text{ teeth} / 60 \\ &= 10 \times 2 / 60 = 0.333 \text{ Hz}\end{aligned}$$

Then, the period (time in seconds between pulses) is calculated as:

$$\begin{aligned}\text{Period} &= 1 / \text{Frequency} \\ &= 1 / 0.333 = 3 \text{ seconds}\end{aligned}$$

In this example, the pulses would be received in time intervals of once every 3 seconds or longer. The Max Wave Duration can be configured to a maximum value of 10,000 milliseconds (10 seconds) to allow for this low speed range. Any pulse not received within 10 seconds would be considered a sensor fault.

- Note that the default value of 1000 Milliseconds (1 second) is correct for most applications.

Signal Lost (SST7100 only)

The Signal Lost function is defined as the absolute maximum allowable period (time between input pulses in milliseconds) before an under speed relay is tripped. Similar to the Max Wave Duration described in the previous step, the Signal Lost setting is necessary for low speed applications where there is a programmed under speed trip. This setting should be set longer than the period (in milliseconds) of the under speed setpoint.

- Enable
 - Check this box to enable Signal Lost
 - If there is no under speed setpoint, leave un-checked
- Timeout
 - This is the maximum time (in milliseconds) allowed before an under speed trip is initiated.
- Trip
 - Select Setpoint 1 for the SST7100

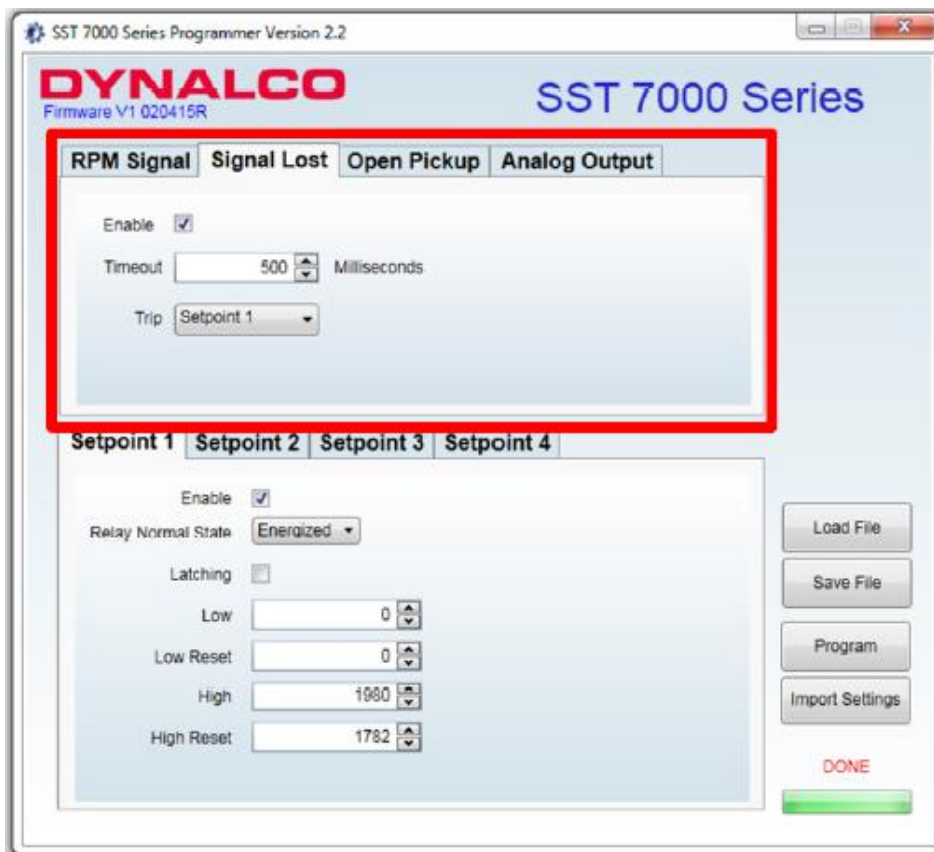

Open Pickup (SST7100 only)

The Open Pickup tab allows the user to select which relay (if any) will activate if an open pickup is sensed.

- Enable
 - Check this box to enable Open Pickup option
- Trip
 - Select Setpoint 1 for the SST7100



Analog Output

The analog output tab is used to define the RPM range of the proportional 4 – 20 mA output.

- RPM Zero
 - Set to the RPM value corresponding to 4 mA output.
 - Normally set to 0 RPM but can be set to any value as long as it is lower than the RPM span.
- RPM Span
 - Set to the RPM value corresponding to 20 mA output.

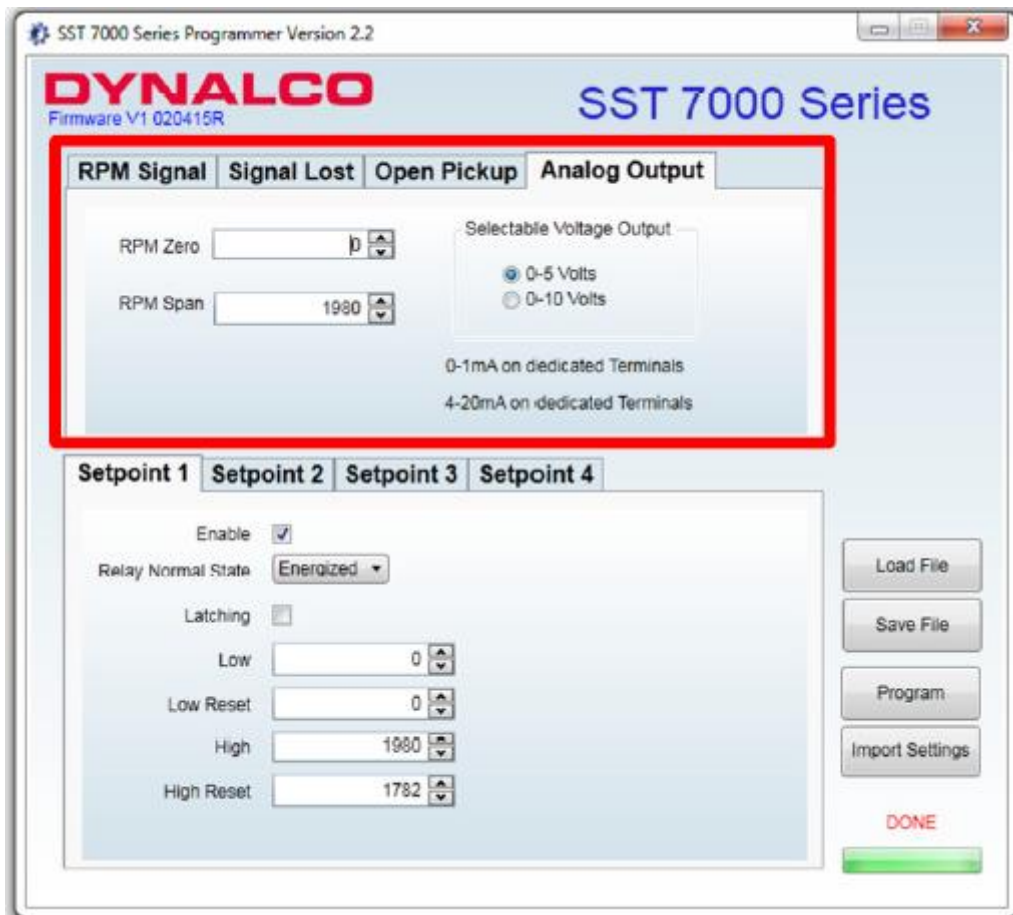

Setpoint 1 (SST7100 only)

The Setpoint 1 tab allows configuration of the relay setpoint and relay logic for the single relay on the SST7100.

- Enable
 - Check this box to enable setpoint 1
- Relay Normal State
 - This is the normal relay state when not tripped
 - Either select normally Energized or normally De-Energized



WARNING:

For critical applications, it is highly recommended to configure the Relay Normal State as “normally Energized.” This configuration will cause the contacts to switch in the event of a relay coil failure.

- Latching
 - Un-check this box to select non-latching relay (auto-reset following trip)
 - Check this box to select latching relay (must be manually reset following trip)
 - A momentary contact from DIG IN (digital input) to VIN GND (supply ground) will reset latching relay
- Low RPM
 - Selects under speed setpoint
 - Set to 0 if no under speed setpoint required
- Reset Low RPM
 - Defines the reset value following an under speed trip
 - Must be set at least 1% higher than Low RPM value to prevent relay chatter
 - Set to 0 if no under speed setpoint required
- High RPM
 - Selects over speed setpoint
- Reset High RPM
 - Defines the reset value following an over speed trip
 - Must be set at least 1% lower than High RPM value to prevent relay chatter

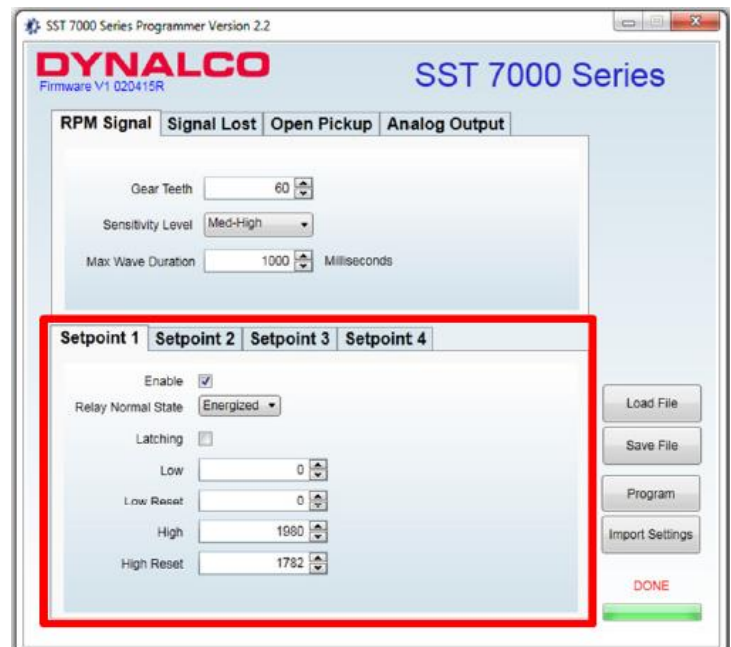

Program

Following initial configuration of the unit or any setting changes, you will need to select “Program” to program the new settings to the SST7000 / SST7100.

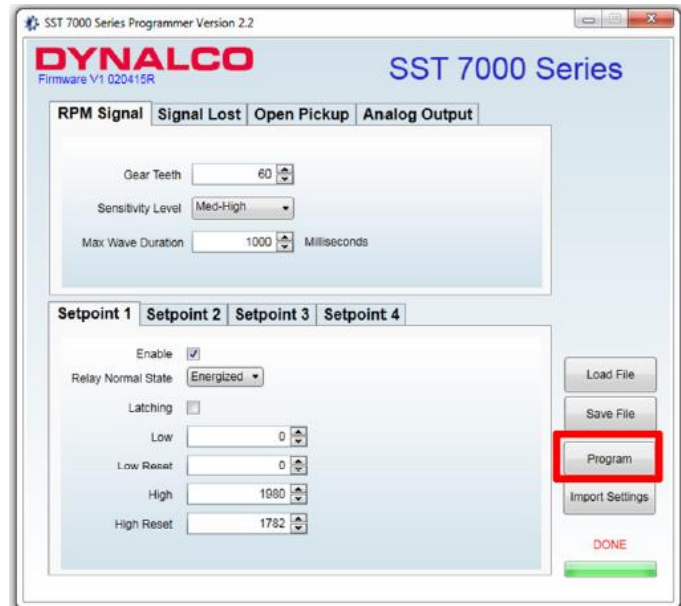

Save File

Selecting “Save File” allows the new settings to be saved to a file location on the PC.

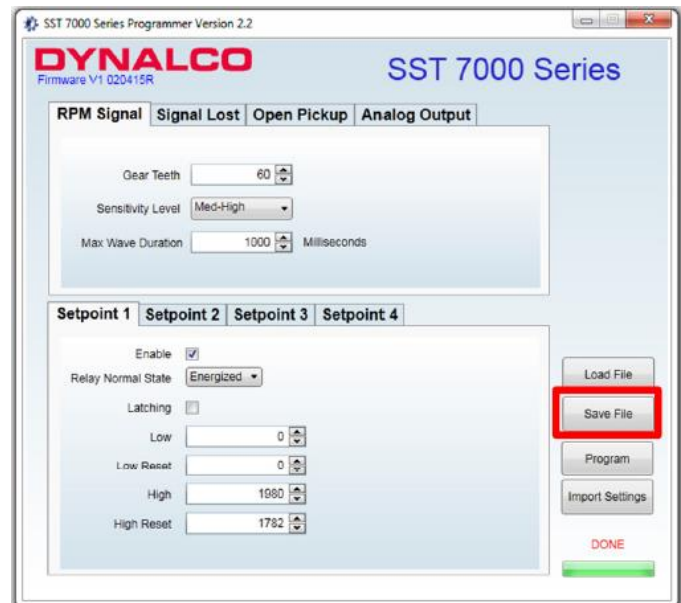

Load File

Any spec files that have been saved to the PC can be loaded to the SST7000 application by selecting “Load File.”

Following this, you will need to select “Program” to write the new configuration to the SST7000.

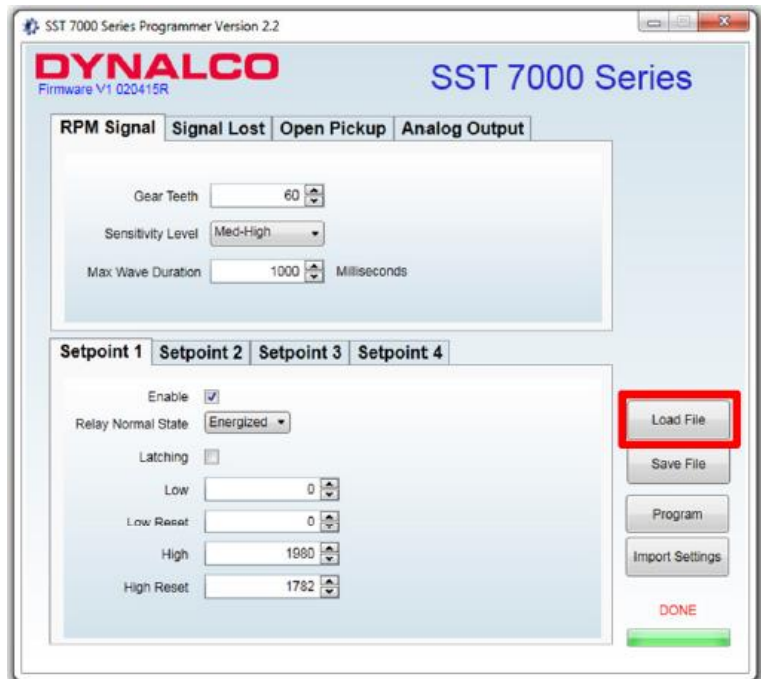

Import Settings

Selection of “Import Settings” will upload the current settings to be read by the SST7000 series software.

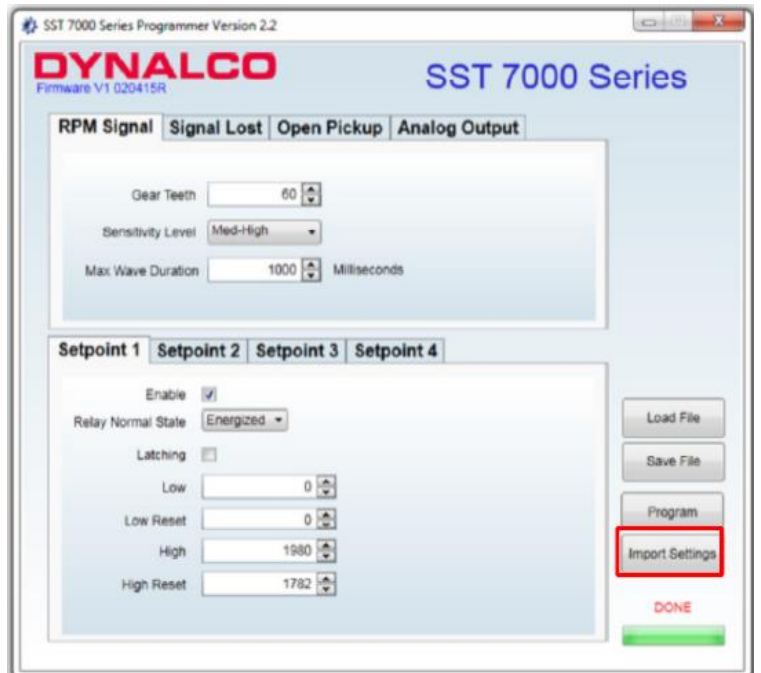

WARNING:

The relay output on the SST7100 should be tested monthly for proper operation, especially if being used for engine overspeed shutdown or other critical function.



- **This equipment is suitable for installation in Class I, Division 2, Groups A, B, C, and/or D hazardous locations, or nonhazardous locations only.**
- **“WARNING - EXPLOSION HAZARD - Substitution of components may impair suitability for Class I, Division 2.”**
- **“AVERTISSEMENT - RISQUE D'EXPLOSION - La substitution de composants peut rendre ce matériel inacceptable pour les emplacements de Classe I, Division 2.”**
- **“WARNING - EXPLOSION HAZARD - Do not connect or disconnect while circuit is live unless area is known to be nonhazardous.”**
- **“AVERTISSEMENT - RISQUE D'EXPLOSION - Ne pas brancher ou débrancher tant que le circuit est sous tension, à moins qu'il ne s'agisse d'un emplacement non dangereux.”**
- **“WARNING - EXPLOSION HAZARD - Do not use USB port (COMM port) unless area is known to be non-hazardous.”**
- **“AVERTISSEMENT - RISQUE D'EXPLOSION - Ne pas utiliser le port USB (port “COMM”) à moins que la zone est connue pour être non dangereux.”**

CONNECTIONS FOR SST7000, SST7000-I, SST7100 AND SST7100-I

WARNING - EXPLOSION HAZARD :
 SUBSTITUTION OF COMPONENTS MAY IMPAIR SUITABILITY FOR
 CLASS I, DIVISION 2.

REVISIONS			
LTR	DESCRIPTION	DATE	APPD
A	PCO 9431, Initial Release	1/16/2015	JLR.

WARNING:
 DO NOT CONNECT OR DISCONNECT UNLESS POWER HAS BEEN
 SWITCHED OFF OR THE AREA IS KNOWN TO BE NON-HAZARDOUS.
 PICKUP MUST BE CONNECTED TO THE SST7000 SERIES DEVICE
 OR TO A LOAD IMPEDANCE LESS THAN 100 K OHMS.

⚠ USB CAN ONLY BE CONNECTED IF AREA
 IS KNOWN TO BE NON-HAZARDOUS

0-5/10V OUTPUT SIGNAL
 LOAD MUST BE GREATER THAN 20K OHM

DIGITAL INPUT: OPEN DRY CONTACT THAT
 WHEN CLOSED WILL GROUND THIS PIN
 AND RESET LATCHED ALARM

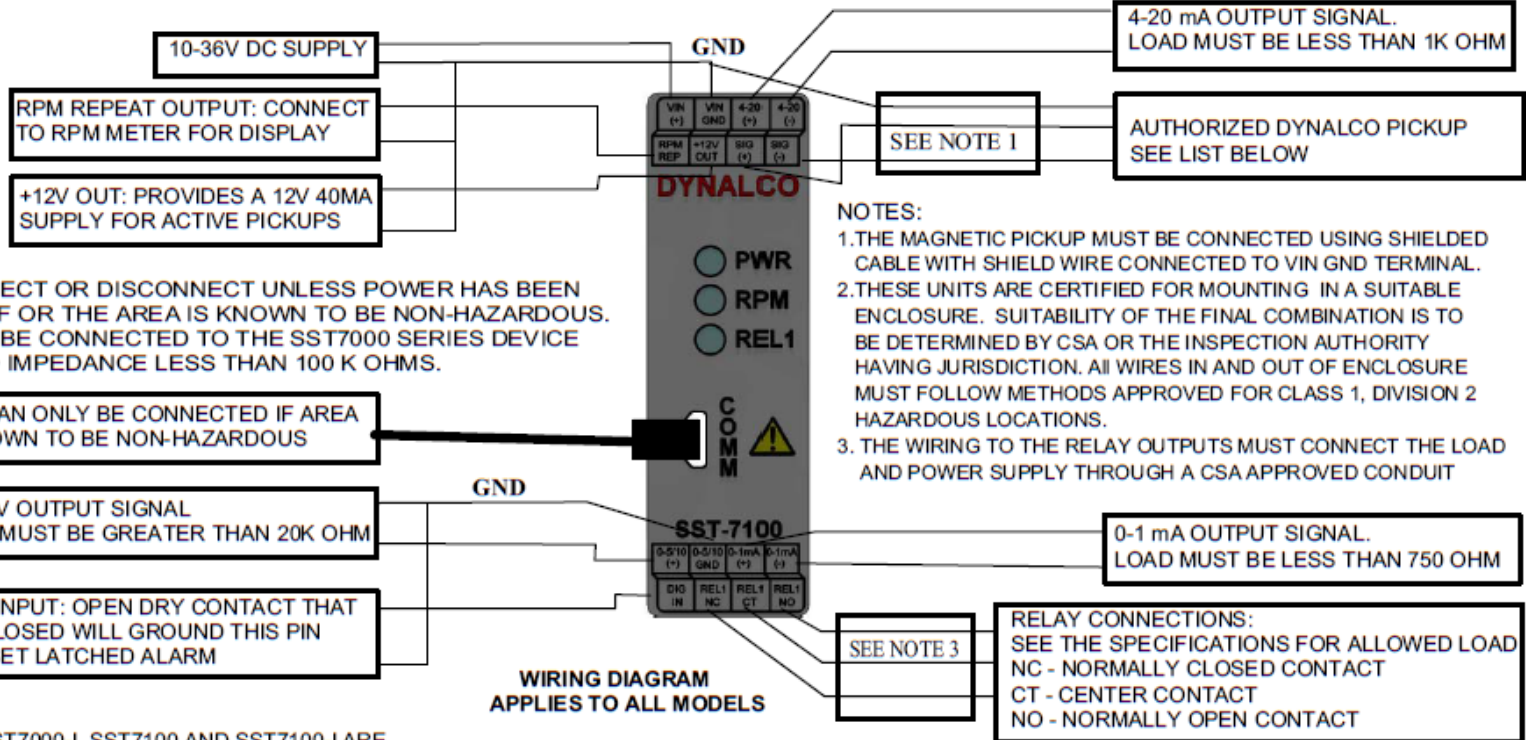

NOTES:

1. THE MAGNETIC PICKUP MUST BE CONNECTED USING SHIELDED CABLE WITH SHIELD WIRE CONNECTED TO VIN GND TERMINAL.
2. THESE UNITS ARE CERTIFIED FOR MOUNTING IN A SUITABLE ENCLOSURE. SUITABILITY OF THE FINAL COMBINATION IS TO BE DETERMINED BY CSA OR THE INSPECTION AUTHORITY HAVING JURISDICTION. ALL WIRES IN AND OUT OF ENCLOSURE MUST FOLLOW METHODS APPROVED FOR CLASS 1, DIVISION 2 HAZARDOUS LOCATIONS.
3. THE WIRING TO THE RELAY OUTPUTS MUST CONNECT THE LOAD AND POWER SUPPLY THROUGH A CSA APPROVED CONDUIT

THE SST7000, SST7000-I, SST7100 AND SST7100-I ARE
 CSA CERTIFIED FOR USE IN **CLASS I, DIVISION 2,**
GROUPS A, B, C, & D LOCATIONS WHEN POWERED
 BY A DYNALCO M 201, M 202, M 231, M 233, M 203, M 204,
 M 205, M 928, M 928-24 & M 951 PICKUPS.

THIS DOCUMENT, ALL INFORMATION CONTAINED HEREIN, AND ALL
 INFORMATION RELATED THERETO, IS THE PROPERTY OF DYNALCO
 CONTROLS (A UNIT OF CRANE CORPORATION), IS CONFIDENTIAL
 TO IT AND NO PART THEREOF NOR ANY SUCH INFORMATION MAY
 BE COPIED, DISSEMINATED OR USED IN SUCH A MANNER
 WHATSOEVER WITHOUT THE PRIOR WRITTEN CONSENT OF
 DYNALCO AND IS TO BE RETURNED TO DYNALCO UPON REQUEST.

N:\PRODUCTS\DSS\DWG\A_800-13092_01_REVA.dsf

DO NOT SCALE THIS DRAWING

UNLESS OTHERWISE SPECIFIED DIMENSIONS ARE IN INCHES AND TOLERANCES ARE:			
FRACT. +/- 1/64	DEC. .XXX +/- .005 XX +/- .01	ANGLES +/- 1/2 DEGREE	
MATERIAL:		<h1 style="text-align: center;">DYNALCO</h1>	
FINISH:			
PRODUCT/PART SST7000, SST7000-I SST7100, SST7100-I		DRAWN Jose Rivero	DATE 3/5/15
		APPROVED	
TITLE INTERCONNECTION DRAWING FOR CSA CERTIFIED UNITS			
SCALE	SIZE	DRAWING NUMBER	REV.
	A	800-13092 SHT. 1 OF 1	A